

Older Model TLS-2/3 Transmission Level Modification for High Speed Modems

These relatively simple changes to the TLS-3 solve high speed modem problems (errors caused by impedance mismatch and echo).

The change would move the TLS-3 impedance toward 600Ω, increase the insertion loss (end-to-end) from around 2 dB to around 8.5 dB (600Ω). (Similar to end-to-end loss on two more or less average subscriber lines.) There are two known regrettable shortcomings.

1. A decrease in available loop current.
The resultant loop current will still be more than 29 mA, but will not support extended loop lengths.
2. Dial tone and busy tone level will be increased.
This can be corrected by an additional value change, but it appears to be equalized between the two ports.

Refer to Figure 1 for the following changes.

To modify your unit to correct these problems, do the following:

1. Change the battery feed resistance from 200Ω (per side) to 390Ω. This increases the basic line impedance. Change resistors R4, R5, R12, and R13 to 390Ω with a 5 watt power rating.
2. Add 300Ω resistors in series with each of the line-to-line coupling capacitors, C1 and C2, to decrease the end-to-end loading on the signal source, and inject the end-to-end loss. Lift the positive side of each capacitor and add the 300 Ω ½W resistor.
3. Change the value of R41 to correct the dial tone level for the new line impedances, if required. R41 is selected from between 51 KΩ and 270 KΩ during assembly to achieve a dial tone level of 92-164 mVRMS per tone into a 600Ω load (approximately -18 dBm).

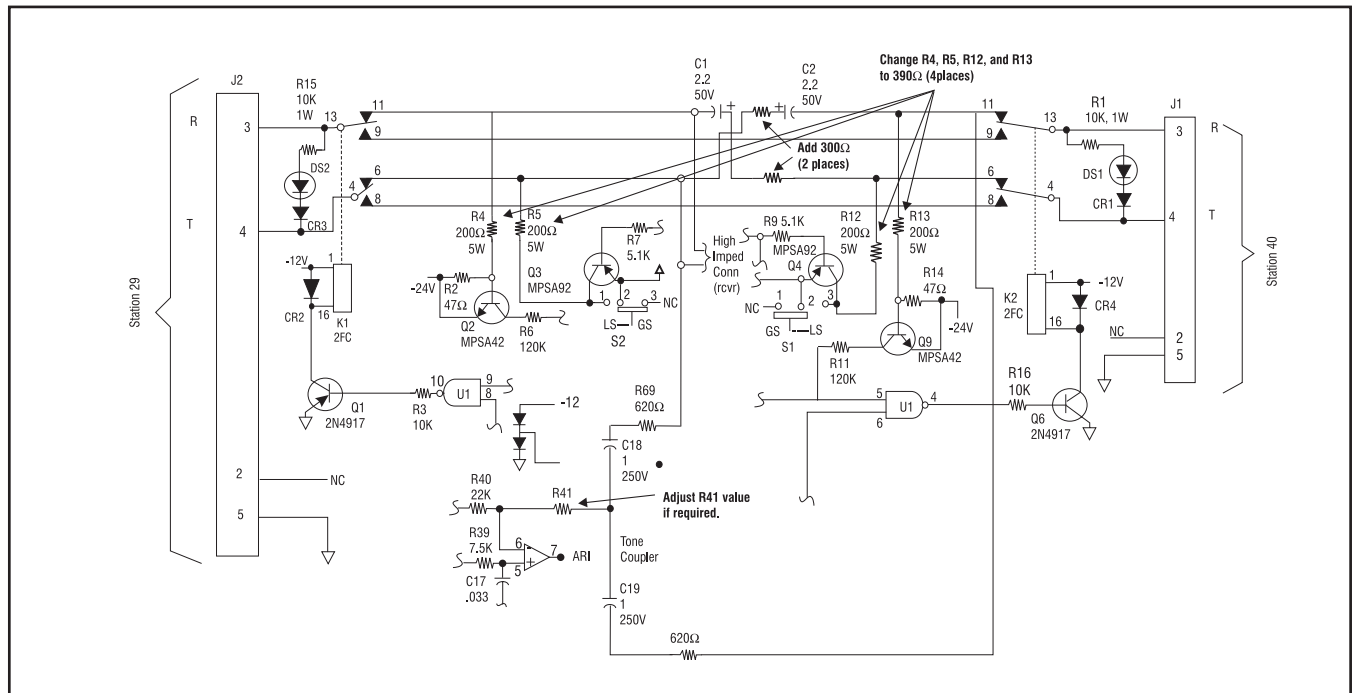

Figure 1 Schematic Diagram

DISCLAIMER

Please be aware that customers may perform this modification at their own risk. Modifications may cause your Teltone product to operate outside of advertised specifications. Any modification (including those documented in the application note) to a unit under warranty will void the warranty and any damages will not be covered under warranty. Any repair costs will be billed as "Out of Warranty".