

Teltone Corporation
White Paper

**Extending the Analog Interface
of the
Telecom Simulation Platform**

November 2000

1. Purpose

The Teltone Telecom Simulation Platform (TSP) supports up to 2 digital interfaces (T1/E1 DS1 channels, each with 24/30 DS0 sub-channels) and up to 8 analog interfaces, or up to 16 analog interfaces if digital interfaces are not required. These interface capabilities are well suited for most product development, application testing and production testing environments where the primary interface needed is at the digital DS1 level. For products that have high number of analog interfaces and/or different types of analog interfaces, such as Integrated Access Devices (IAD) that have 24 or more analog POTS interfaces, a slightly different solution is needed.

This purpose of this White Paper is to present a flexible and cost-effective way to extend the analog interface capabilities of the TSP through the use of off-the-shelf Channel Banks. The information provided here is high level in nature and is intended to help the readers in quickly determining the suitability of this solution for their applications. Additional detailed level information will be provided in the form of Applications Notes to guide the users in configuring the TSP and specific Channel Banks.

The structure of this White Paper is as follows:

- Section 2 explains the built-in interfaces available from the TSP.
- Section 3 examines the extended analog interfaces provided through the use of a Channel Bank – increasing the number and type of analog interfaces.
- Section 4 illustrates how to control multiple TSP units to further increase the overall capabilities.
- Section 5 presents a sample application to demonstrate the use of extended analog interfaces for production testing of an IAD.

2. Basic Interface Capabilities of the Telecom Simulation Platform

The TSP is designed to accommodate up to 2 interface modules –digital modules (2 versions) and analog modules (2 versions). The combination of these modules allows the TSP to simulate up to 2 digital channels (DS1) with up to 8 analog loop-start FXS¹ channels (DS0), or up to 16 analog loop-start FXS channels with no digital channels.

The diagram below illustrates the module types, the number of digital and analog interfaces, and the signaling protocols supported:

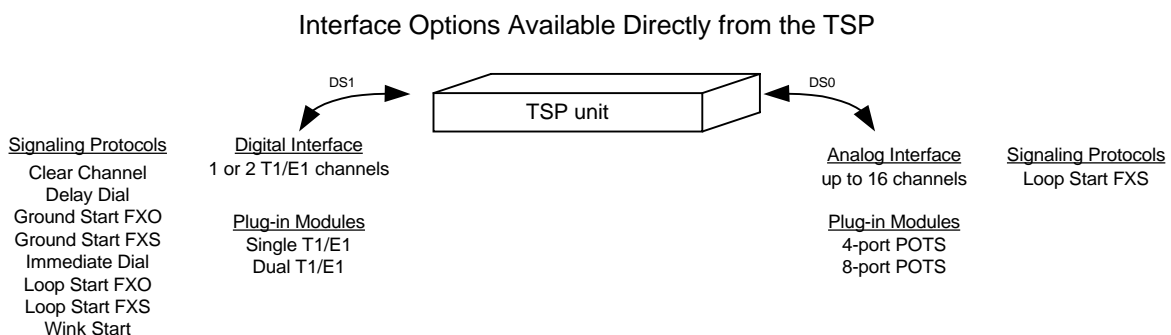

Each digital and analog channel can be configured to originate or terminate calls or to connect end-to-end to another channel within the TSP unit.

¹ Foreign Exchange Station (FXS) protocol is used by an office to communicate with a station – **FXS behaves like a phone line**. While Foreign Exchange Office (FXO) protocol is used by a station to communicate with an office – **FXO behaves like a telephone**.

3. Extending the Analog Interface Capabilities of the Telecom Simulation Platform

Although the TSP only supports a limited number of Analog loop start FXS channels (simulating the phone line from a CO), it is possible to extend the analog capabilities of the TSP to more channels and with different signaling protocols – including FXS loop-start and ground-start, FXO loop-start and ground-start, and 2-wire/4-wire E&M, by connecting a Channel Bank to the digital interface of the TSP.

A Channel Bank is a multiplexer that provides individual sub-channels (DS0 channels) from a high speed multiplexed digital channel (DS1). The number of DS0 channels available depends on whether the DS1 is T1 (North America) or E1 (most of other regions) – 24 DS0 for T1, and 30 DS0 for E1. The interface of each DS0 channel can be digital (e.g. V.35) or analog (e.g. FXO). For this application, the Channel Bank will be equipped with analog DS0 channels of the type that is compatible with the Unit Under Test (UUT).

Modern Channel Banks are widely available that offer compact packaging (e.g. 17” x 18” x 2”) and low cost (under \$200 per DS0 channel). The DS1 connection is usually via a standard RJ-48C jack. The DS0 connections are typically via an industry-standard 25-pair jack. Most Channel Banks can support wall or rack mount.

The diagram below illustrates extended analog interfaces provided by 1 or 2 Channel Banks.

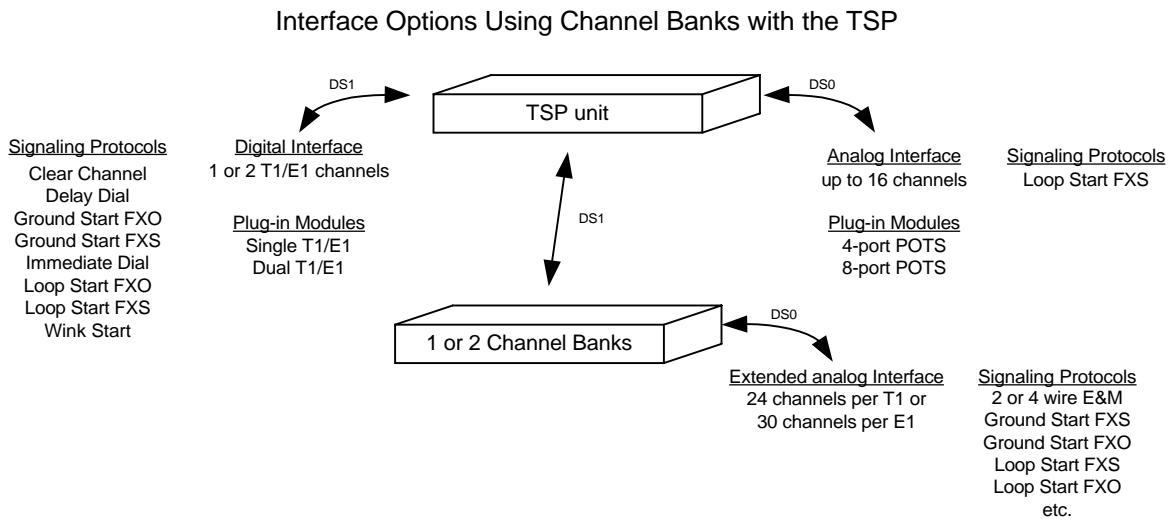

4. Extending the testing capabilities further using multiple TSP units.

Multiple TSP units can be configured and controlled by a single PC via an Ethernet connection, as shown in the diagram below. This capability provides a powerful way to manage multiple test stations by a single PC, and to meet the interface requirements of a large system – with many digital and analog interfaces.

Teltone Application Note #102, available on the Teltone web site, provides details of setting up Ethernet connections for multiple TSP units.

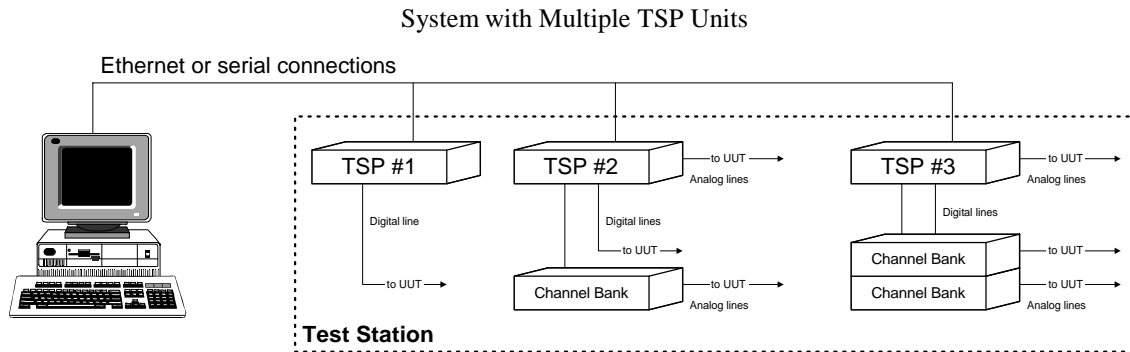

5. Sample Application with a Channel Bank Acting as an Extension of the TSP

Block Diagram and Simplified Test Scenario Map

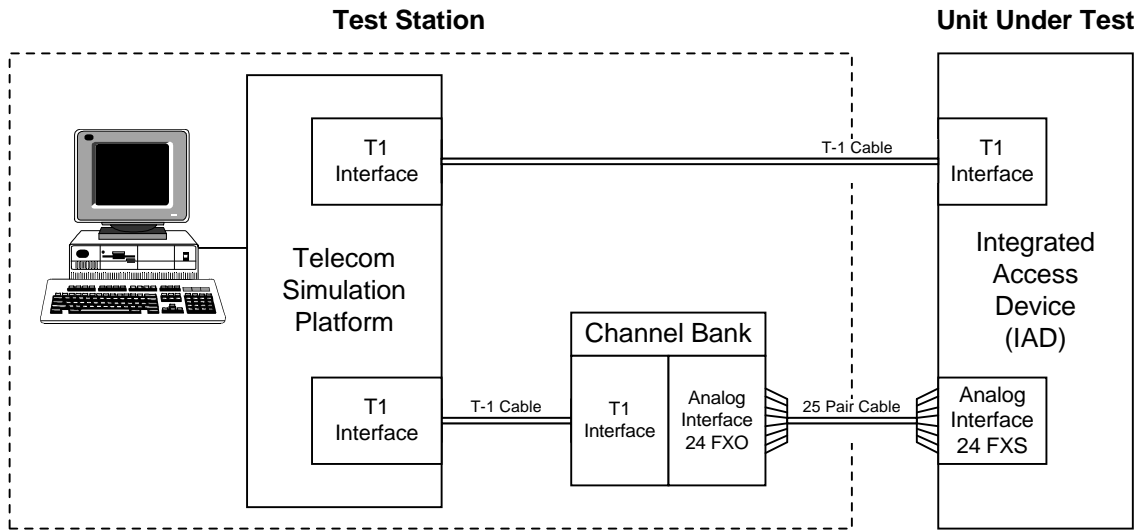

The above diagram illustrates how a powerful and cost effective Test Station can be put together to test a common Integrated Access Device (IAD). In this example, the Unit Under Test (UUT) has one T1 digital interface and 24 FXS (POTS) analog interfaces. The test philosophy is to verify the functionality of UUT with each interface thoroughly checked for proper operations, in as close to real world environment as possible. Test time is to be kept to a minimum through the use of test automation.

To accomplish these objectives, a Test Station is constructed consisting of a TSP equipped with a Dual T1 module and a Channel Bank equipped with a single T1 interface and 24 FXO interfaces. One of two T1 interfaces from the TSP is connected to the Channel Bank and the other T1 interface is connected directly to the T1 interface of the UUT (via a standard T1 cable). The FXO interfaces of the Channel Bank are connected to the FXS interfaces of the UUT (via a standard 25-pair cable). A Windows-based PC is connected to the TSP via an Ethernet connection (directly or via a network hub). Through the provided TSP software, the PC can configure the TSP to originate calls from one T1 interface and terminate calls on the other T1 interface on a per DS0 channel level – thus checking the operations of each analog channel.

The following steps are recommended to complete the test setup:

- To ensure proper communications between the TSP, Channel Bank, and UUT, each T1 interface needs to be correctly configured for matching line coding (AMI or B8ZS), framing (D4 or ESF) and clock sourcing (internal or external). For this application, the TSP is used to simulate the network. It is therefore recommended that the TSP provides the master clock with both the Channel Bank and the UUT configured to use external clock (from the TSP).
- The next step is to determine the tests intended to be performed and the signaling protocols to be used for communication by each channel. A detailed scenario map is a very useful tool for designing and organizing comprehensive test scenarios, which can include specific channel assignments for each control set, protocol assignments for those channels, and the digit string assignments.
- Each detailed scenario map should contain all operations intended to occur simultaneously. These operations can then be configured in a single Project file. Operations that cannot occur simultaneously should be divided into separate scenario maps and saved in separate Project files to allow quick transitions between desired operations.